

REVISION HISTORY

REV	DESCRIPTION	DATE	APPROVED

SCALE
1:2.5

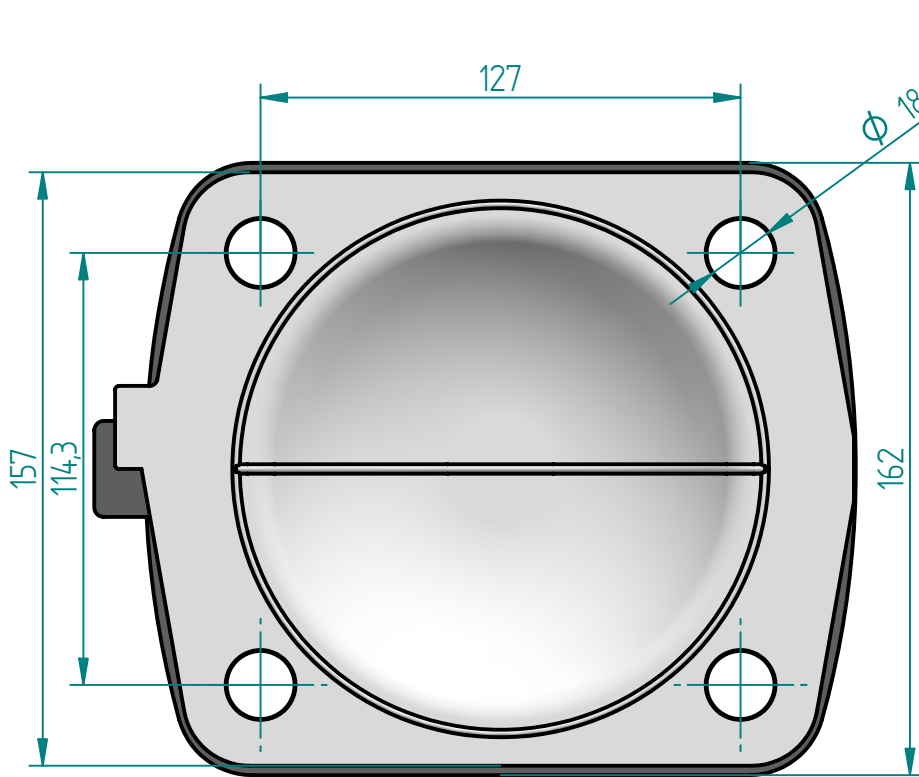
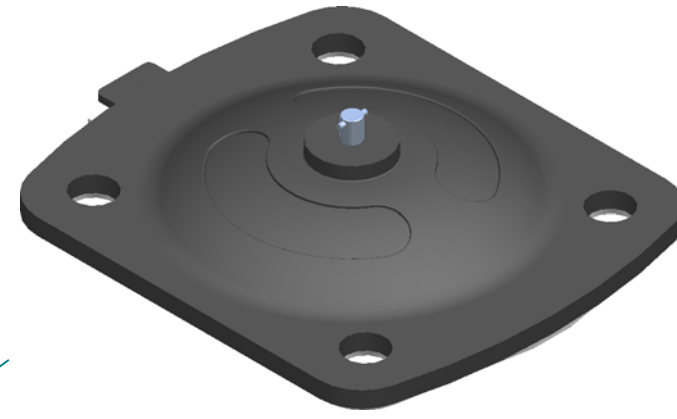
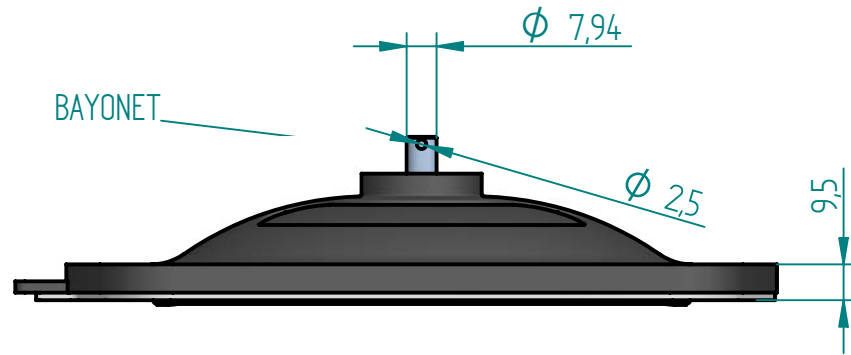

Replacement Diaphragm for :-

OEM PART = 3.000-P3

USED ON 3" (DN80) Diaphragm Valve

	NAME	DATE
DRAWN	M. MC KEON	01/12/15
CHECKED		



Material -
FPM BACKING TFM-
DIAPHRAGM

Complies with CFR 177.2600
and Conforms to
USP Class VI Biological Reactivity
Tests Section #87 and #88

TITLE
DD30-STFM-FPM

SIZE A	FOOT PRINT DIMENSIONS	REV A
-----------	-----------------------	----------

FILE NAME: DD30-STFM-FPM.dft

SCALE: 1:2 (mm)	ECO:0605	SHEET 1 OF 1
-----------------	----------	--------------

Disclaimer - Diaphragm Direct® does not manufacture, represent, nor sell OEM valves or diaphragms manufactured by any other company. Diaphragm Direct® brand diaphragms are not sponsored by any other manufacturers. Any name, model, part number, brand, image, material or referral is for descriptive purposes only. Diaphragm Direct® brand replacement diaphragms are guaranteed to fit OEM equipment and meet or exceed OEM specifications. Diaphragm Direct® brand replacement diaphragms are covered by the standard Diaphragm Direct® limited product warranty.